

DATA SHEET

74ALVC04 Hex inverter

Preliminary specification
File under Integrated Circuits, IC24

2002 Apr 16

Hex inverter

74ALVC04

FEATURES

- Wide supply voltage range of 1.65 to 3.6 V
- Complies with JEDEC standard:
JESD8-7 (1.65 to 1.95 V)
JESD8-5 (2.3 to 2.7 V)
JESD8B/JESD36 (2.7 to 3.6 V)
- 3.6 V tolerant inputs/outputs
- CMOS LOW power consumption
- Direct interface with TTL levels (2.7 to 3.6 V)
- Power down mode
- Latch-up performance exceeds ≤ 250 mA
- ESD protection:
2000 V Human Body Model (A 114-A)
200 V Machine Model (A 115-A).

DESCRIPTION

The 74ALVC04 is a high-performance, low-power, low-voltage, Si-gate CMOS device and superior to most advanced CMOS compatible TTL families.

Schmitt-trigger action at all inputs makes the circuit tolerant for slower input rise and fall times.

The 74ALVC04 provides six inverting buffers.

QUICK REFERENCE DATA

GND = 0 V; $T_{amb} = 25$ °C.

SYMBOL	PARAMETER	CONDITIONS	TYP.	UNIT
t_{PHL}/t_{PLH}	propagation delay inputs nA to output nY	$V_{CC} = 1.8$ V; $C_L = 30$ pF; $R_L = 1$ k Ω	2.4	ns
		$V_{CC} = 2.5$ V; $C_L = 30$ pF; $R_L = 500$ Ω	1.8	ns
		$V_{CC} = 2.7$ V; $C_L = 50$ pF; $R_L = 500$ Ω	2.3	ns
		$V_{CC} = 3.3$ V; $C_L = 50$ pF; $R_L = 500$ Ω	2.0	ns
C_I	input capacitance		3.5	pF
C_{PD}	power dissipation capacitance per buffer	$V_{CC} = 3.3$ V; notes 1 and 2	26	pF

Notes

1. C_{PD} is used to determine the dynamic power dissipation (P_D in μ W).

$$P_D = C_{PD} \times V_{CC}^2 \times f_i + (C_L \times V_{CC}^2 \times f_o) \text{ where:}$$

f_i = input frequency in MHz;

f_o = output frequency in MHz;

C_L = output load capacitance in pF;

V_{CC} = supply voltage in Volts.

2. The condition is $V_I = \text{GND to } V_{CC}$.

Hex inverter

74ALVC04

ORDERING INFORMATION

TYPE NUMBER	PACKAGES			
	PINS	PACKAGE	MATERIAL	CODE
74ALVC04D	14	SO	plastic	SOT108-1
74ALVC04PW	14	TSSOP	plastic	SOT402-1

FUNCTION TABLE

See note 1.

INPUTS	OUTPUTS
nA	nY
L	H
H	L

Note

- 1. H = HIGH voltage level;
L = LOW voltage level.

PINNING

PIN	SYMBOL	DESCRIPTION
1, 3, 5, 9, 11, 13	1A to 6Y	data inputs
2, 4, 6, 8, 10, 12	1Y to 6Y	data outputs
7	GND	ground (0 V)
14	V _{CC}	DC supply voltage

Hex inverter

74ALVC04

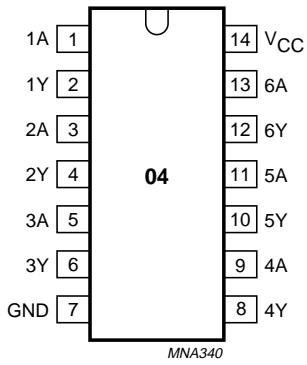

Fig.1 Pin configuration.

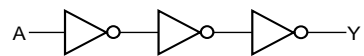

Fig.2 Logic diagram (one inverter).

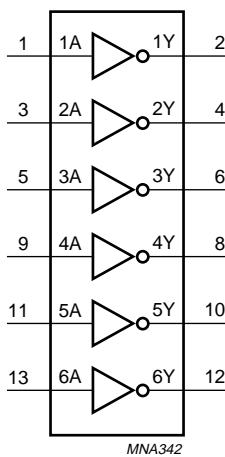

Fig.3 Logic symbol.

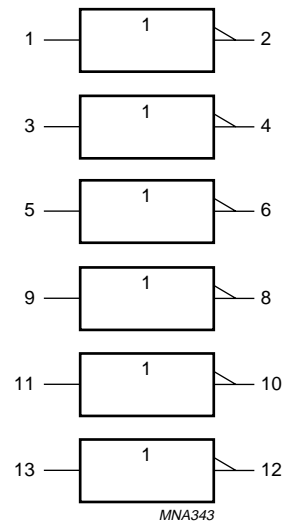

Fig.4 IEC logic symbol.

Hex inverter

74ALVC04

RECOMMENDED OPERATING CONDITIONS

SYMBOL	PARAMETER	CONDITIONS	MIN.	MAX.	UNIT
V_{CC}	supply voltage		1.65	3.6	V
V_I	input voltage		0	3.6	V
V_O	output voltage	$V_{CC} = 1.65$ to 3.6 V; enable mode	0	V_{CC}	V
		$V_{CC} = 1.65$ to 3.6 V; disable mode	0	3.6	V
		$V_{CC} = 0$ V; Power-down mode	0	3.6	V
T_{amb}	operating ambient temperature		-40	+85	°C
t_r, t_f	input rise and fall times	$V_{CC} = 1.65$ to 2.7 V	0	20	ns/V
		$V_{CC} = 2.7$ to 3.6 V	0	10	ns/V

LIMITING VALUES

In accordance with the Absolute Maximum Rating System (IEC 60134); voltages are referenced to GND (ground = 0 V).

SYMBOL	PARAMETER	CONDITIONS	MIN.	MAX.	UNIT
V_{CC}	supply voltage		-0.5	+4.6	V
I_{IK}	input diode current	$V_I < 0$	-	-50	mA
V_I	input voltage		-0.5	+4.6	V
I_{OK}	output diode current	$V_O > V_{CC}$ or $V_O < 0$	-	± 50	mA
V_O	output voltage	enable mode; notes 1 and 2	-0.5	$V_{CC} + 0.5$	V
		disable mode	-0.5	+4.6	V
		Power-down mode; note 2	-0.5	+4.6	V
I_O	output diode current	$V_O = 0$ to V_{CC}	-	± 50	mA
I_{GND}, I_{CC}	V_{CC} or GND current		-	± 100	mA
T_{stg}	storage temperature		-65	+150	°C
P_{tot}	power dissipation per package				
	SO package	above 70 °C derate linearly with 8 mW/K	-	500	mW
	TSSOP package	above 60 °C derate linearly with 5.5 mW/K	-	500	mW

Notes

1. The input and output voltage ratings may be exceeded if the input and output current ratings are observed.
2. When $V_{CC} = 0$ V (Power-down mode), the output voltage can be 3.6 V in normal operation.

Hex inverter

74ALVC04

DC CHARACTERISTICS

At recommended operating conditions; voltages are referenced to GND (ground = 0 V).

SYMBOL	PARAMETER	TEST CONDITIONS		T _{amb} (°C)			UNIT
		OTHER	V _{CC} (V)	-40 to +85			
				MIN.	TYP. ⁽¹⁾	MAX.	
V _{IH}	HIGH-level input voltage		1.65 to 1.95	0.65 × V _{CC}	–	–	V
			2.3 to 2.7	1.7	–	–	V
			2.7 to 3.6	2	–	–	V
V _{IL}	LOW-level input voltage		1.65 to 1.95	–	–	0.35 × V _{CC}	V
			2.3 to 2.7	–	–	0.7	V
			2.7 to 3.6	–	–	0.8	V
V _{OL}	LOW-level output voltage	V _I = V _{IH} or V _{IL} ; I _O = 100 μA	1.65 to 3.6	–	–	0.2	V
		V _I = V _{IH} or V _{IL} ; I _O = 6 mA	1.65	–	0.11	0.3	V
		V _I = V _{IH} or V _{IL} ; I _O = 12 mA	2.3	–	0.17	0.4	V
		V _I = V _{IH} or V _{IL} ; I _O = 18 mA	2.3	–	0.25	0.6	V
		V _I = V _{IH} or V _{IL} ; I _O = 12 mA	2.7	–	0.16	0.4	V
		V _I = V _{IH} or V _{IL} ; I _O = 18 mA	3.0	–	0.23	0.4	V
		V _I = V _{IH} or V _{IL} ; I _O = 24 mA	3.0	–	0.30	0.55	V
V _{OH}	HIGH-level output voltage	V _I = V _{IH} or V _{IL} ; I _O = –100 μA	1.65 to 3.6	V _{CC} – 0.2	–	–	V
		V _I = V _{IH} or V _{IL} ; I _O = –6 mA	1.65	1.25	1.51	–	V
		V _I = V _{IH} or V _{IL} ; I _O = –12 mA	2.3	1.8	2.10	–	V
		V _I = V _{IH} or V _{IL} ; I _O = –18 mA	2.3	1.7	2.01	–	V
		V _I = V _{IH} or V _{IL} ; I _O = –12 mA	2.7	2.2	2.53	–	V
		V _I = V _{IH} or V _{IL} ; I _O = –18 mA	3.0	2.4	2.76	–	V
		V _I = V _{IH} or V _{IL} ; I _O = –24 mA	3.0	2.2	2.68	–	V
I _I	input leakage current	V _I = 3.6 V or GND	3.6	–	±0.1	±5	μA
I _{off}	power OFF leakage current	V _I or V _O = 3.6 V	0.0	–	±0.1	±10	μA
I _{CC}	quiescent supply current	V _I = V _{CC} or GND; I _O = 0	3.6	–	0.2	20	μA
ΔI _{CC}	additional quiescent supply current per input pin	V _I = V _{CC} – 0.6 V; I _O = 0	3.0 to 3.6	–	5	750	μA

Note

1. All typical values are measured at V_{CC} = 3.3 V and T_{amb} = 25 °C.

Hex inverter

74ALVC04

AC CHARACTERISTICS

SYMBOL	PARAMETER	TEST CONDITIONS		T _{amb} (°C)			UNIT
		WAVEFORMS	V _{CC} (V)	-40 to +85			
				MIN.	TYP. ⁽¹⁾	MAX.	
t _{PHL} /t _{PLH}	propagation delay nA to nY	see Figs 5 and 6	1.65 to 1.95	1.0	2.4	4.4	ns
			2.3 to 2.7	1.0	1.8	3.0	ns
			2.7	1.0	2.3	3.3	ns
			3.0 to 3.6	1.0	2.0	2.8	ns

Note

1. All typical values are measured at T_{amb} = 25 °C.

AC WAVEFORMS

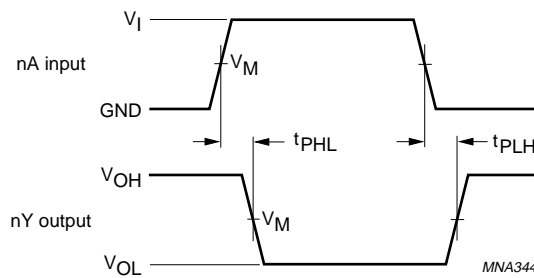

V _{CC}	V _M	INPUT	
		V _I	t _r = t _f
1.65 to 1.95 V	0.5 × V _{CC}	V _{CC}	≤ 2.0 ns
2.3 to 2.7 V	0.5 × V _{CC}	V _{CC}	≤ 2.0 ns
2.7 V	1.5 V	2.7 V	≤ 2.5 ns
3.0 to 3.6 V	1.5 V	2.7 V	≤ 2.5 ns

Fig.5 Inputs nA to output nY propagation delay times.

Hex inverter

74ALVC04

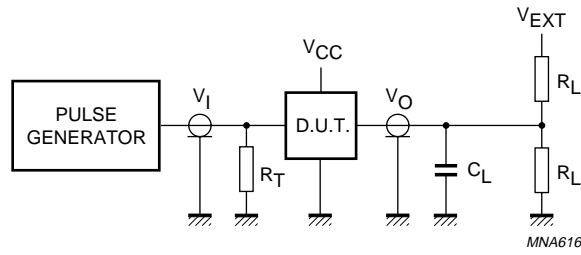

V _{CC}	V _I	C _L	R _L	V _{EXT}		
				t _{PLH} /t _{PHL}	t _{PZH} /t _{PHZ}	t _{PZL} /t _{PLZ}
1.65 to 1.95 V	V _{CC}	30 pF	1 kΩ	open	GND	2 × V _{CC}
2.3 to 2.7 V	V _{CC}	30 pF	500 Ω	open	GND	2 × V _{CC}
2.7 V	2.7 V	50 pF	500 Ω	open	GND	6 V
3.0 to 3.6 V	2.7 V	50 pF	500 Ω	open	GND	6 V

R_L = Load resistor.

C_L = Load capacitance including jig and probe capacitance.

R_T = Termination resistance should be equal to the output impedance Z_o of the pulse generator.

Fig.6 Load circuitry for switching times.

Hex inverter

74ALVC04

PACKAGE OUTLINE

SO14: plastic small outline package; 14 leads; body width 3.9 mm

SOT108-1

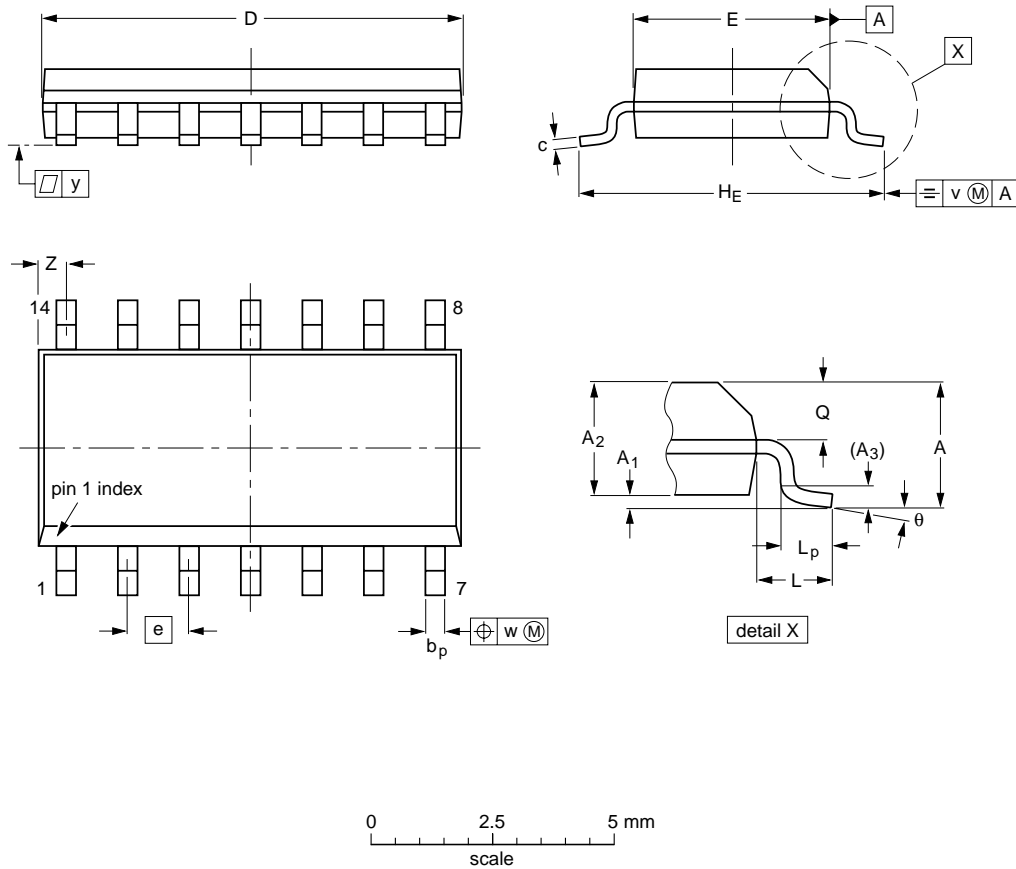

DIMENSIONS (inch dimensions are derived from the original mm dimensions)

UNIT	A max.	A ₁	A ₂	A ₃	b _p	c	D ⁽¹⁾	E ⁽¹⁾	e	H _E	L	L _p	Q	v	w	y	Z ⁽¹⁾	θ
mm	1.75	0.25 0.10	1.45 1.25	0.25	0.49 0.36	0.25 0.19	8.75 8.55	4.0 3.8	1.27	6.2 5.8	1.05	1.0 0.4	0.7 0.6	0.25	0.25	0.1	0.7 0.3	8° 0°
inches	0.069	0.010 0.004	0.057 0.049	0.01	0.019 0.014	0.0100 0.0075	0.35 0.34	0.16 0.15	0.050	0.244 0.228	0.041	0.039 0.016	0.028 0.024	0.01	0.01	0.004	0.028 0.012	

Note

1. Plastic or metal protrusions of 0.15 mm maximum per side are not included.

OUTLINE VERSION	REFERENCES			EUROPEAN PROJECTION	ISSUE DATE
	IEC	JEDEC	EIAJ		
SOT108-1	076E06	MS-012			97-05-22- 99-12-27

Hex inverter

74ALVC04

TSSOP14: plastic thin shrink small outline package; 14 leads; body width 4.4 mm

SOT402-1

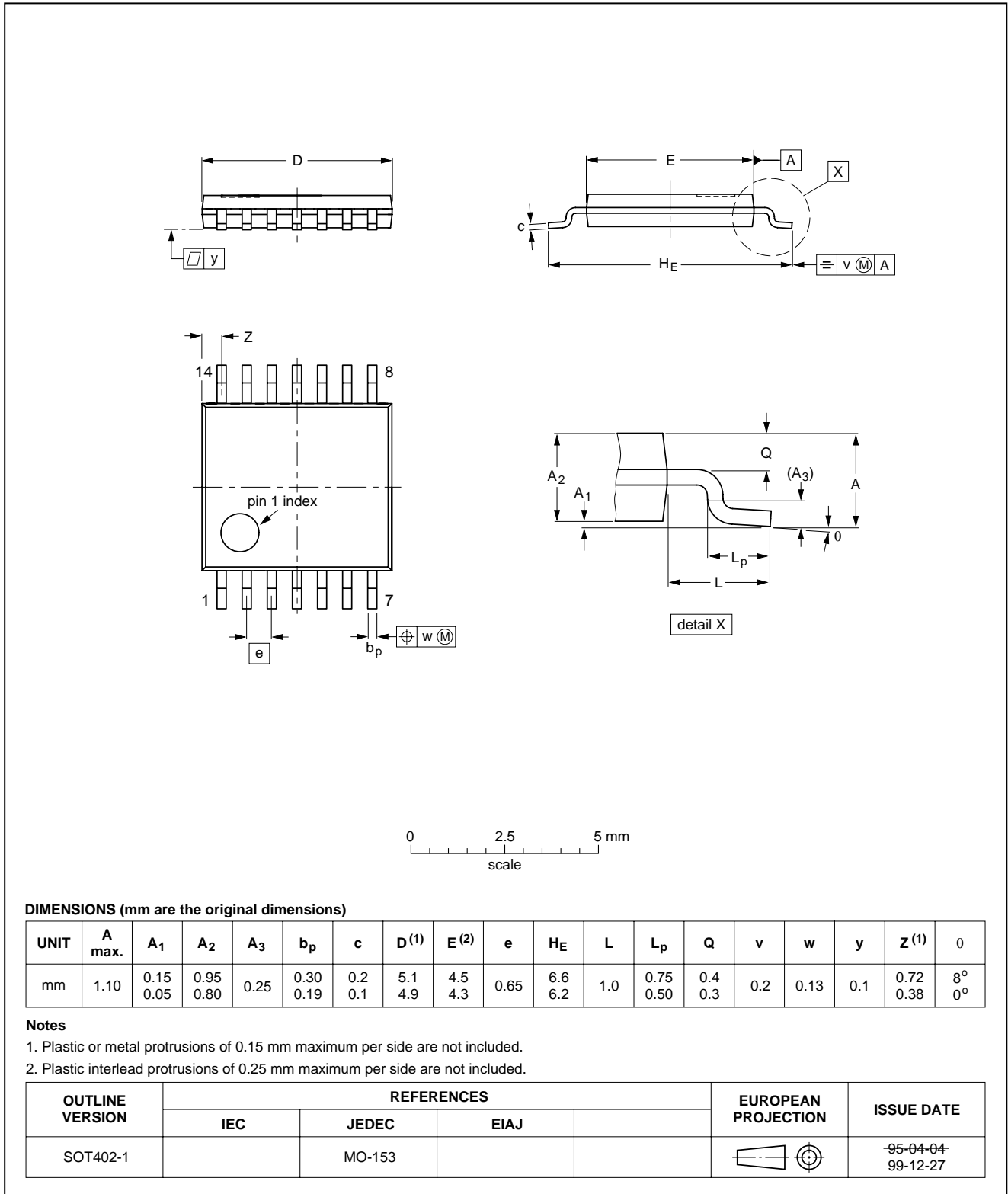

Hex inverter

74ALVC04

SOLDERING**Introduction to soldering surface mount packages**

This text gives a very brief insight to a complex technology. A more in-depth account of soldering ICs can be found in our *"Data Handbook IC26; Integrated Circuit Packages"* (document order number 9398 652 90011).

There is no soldering method that is ideal for all surface mount IC packages. Wave soldering can still be used for certain surface mount ICs, but it is not suitable for fine pitch SMDs. In these situations reflow soldering is recommended.

Reflow soldering

Reflow soldering requires solder paste (a suspension of fine solder particles, flux and binding agent) to be applied to the printed-circuit board by screen printing, stencilling or pressure-syringe dispensing before package placement.

Several methods exist for reflowing; for example, convection or convection/infrared heating in a conveyor type oven. Throughput times (preheating, soldering and cooling) vary between 100 and 200 seconds depending on heating method.

Typical reflow peak temperatures range from 215 to 250 °C. The top-surface temperature of the packages should preferably be kept below 220 °C for thick/large packages, and below 235 °C for small/thin packages.

Wave soldering

Conventional single wave soldering is not recommended for surface mount devices (SMDs) or printed-circuit boards with a high component density, as solder bridging and non-wetting can present major problems.

To overcome these problems the double-wave soldering method was specifically developed.

If wave soldering is used the following conditions must be observed for optimal results:

- Use a double-wave soldering method comprising a turbulent wave with high upward pressure followed by a smooth laminar wave.
- For packages with leads on two sides and a pitch (e):
 - larger than or equal to 1.27 mm, the footprint longitudinal axis is **preferred** to be parallel to the transport direction of the printed-circuit board;
 - smaller than 1.27 mm, the footprint longitudinal axis **must** be parallel to the transport direction of the printed-circuit board.

The footprint must incorporate solder thieves at the downstream end.

- For packages with leads on four sides, the footprint must be placed at a 45° angle to the transport direction of the printed-circuit board. The footprint must incorporate solder thieves downstream and at the side corners.

During placement and before soldering, the package must be fixed with a droplet of adhesive. The adhesive can be applied by screen printing, pin transfer or syringe dispensing. The package can be soldered after the adhesive is cured.

Typical dwell time is 4 seconds at 250 °C.

A mildly-activated flux will eliminate the need for removal of corrosive residues in most applications.

Manual soldering

Fix the component by first soldering two diagonally-opposite end leads. Use a low voltage (24 V or less) soldering iron applied to the flat part of the lead. Contact time must be limited to 10 seconds at up to 300 °C.

When using a dedicated tool, all other leads can be soldered in one operation within 2 to 5 seconds between 270 and 320 °C.

Hex inverter

74ALVC04

Suitability of surface mount IC packages for wave and reflow soldering methods

PACKAGE	SOLDERING METHOD	
	WAVE	REFLOW ⁽¹⁾
BGA, LFBGA, SQFP, TFBGA	not suitable	suitable
HBCC, HLQFP, HSQFP, HSOP, HTQFP, HTSSOP, SMS	not suitable ⁽²⁾	suitable
PLCC ⁽³⁾ , SO, SOJ	suitable	suitable
LQFP, QFP, TQFP	not recommended ⁽³⁾⁽⁴⁾	suitable
SSOP, TSSOP, VSO	not recommended ⁽⁵⁾	suitable

Notes

1. All surface mount (SMD) packages are moisture sensitive. Depending upon the moisture content, the maximum temperature (with respect to time) and body size of the package, there is a risk that internal or external package cracks may occur due to vaporization of the moisture in them (the so called popcorn effect). For details, refer to the Drypack information in the *"Data Handbook IC26; Integrated Circuit Packages; Section: Packing Methods"*.
2. These packages are not suitable for wave soldering as a solder joint between the printed-circuit board and heatsink (at bottom version) can not be achieved, and as solder may stick to the heatsink (on top version).
3. If wave soldering is considered, then the package must be placed at a 45° angle to the solder wave direction. The package footprint must incorporate solder thieves downstream and at the side corners.
4. Wave soldering is only suitable for LQFP, TQFP and QFP packages with a pitch (e) equal to or larger than 0.8 mm; it is definitely not suitable for packages with a pitch (e) equal to or smaller than 0.65 mm.
5. Wave soldering is only suitable for SSOP and TSSOP packages with a pitch (e) equal to or larger than 0.65 mm; it is definitely not suitable for packages with a pitch (e) equal to or smaller than 0.5 mm.

Hex inverter

74ALVC04

DATA SHEET STATUS

DATA SHEET STATUS	PRODUCT STATUS	DEFINITIONS ⁽¹⁾
Objective specification	Development	This data sheet contains the design target or goal specifications for product development. Specification may change in any manner without notice.
Preliminary specification	Qualification	This data sheet contains preliminary data, and supplementary data will be published at a later date. Philips Semiconductors reserves the right to make changes at any time without notice in order to improve design and supply the best possible product.
Product specification	Production	This data sheet contains final specifications. Philips Semiconductors reserves the right to make changes at any time without notice in order to improve design and supply the best possible product.

Note

1. Please consult the most recently issued data sheet before initiating or completing a design.

DEFINITIONS

Short-form specification — The data in a short-form specification is extracted from a full data sheet with the same type number and title. For detailed information see the relevant data sheet or data handbook.

Limiting values definition — Limiting values given are in accordance with the Absolute Maximum Rating System (IEC 60134). Stress above one or more of the limiting values may cause permanent damage to the device.

These are stress ratings only and operation of the device at these or at any other conditions above those given in the Characteristics sections of the specification is not implied. Exposure to limiting values for extended periods may affect device reliability.

Application information — Applications that are described herein for any of these products are for illustrative purposes only. Philips Semiconductors make no representation or warranty that such applications will be suitable for the specified use without further testing or modification.

DISCLAIMERS

Life support applications — These products are not designed for use in life support appliances, devices, or systems where malfunction of these products can reasonably be expected to result in personal injury. Philips Semiconductors customers using or selling these products for use in such applications do so at their own risk and agree to fully indemnify Philips Semiconductors for any damages resulting from such application.

Right to make changes — Philips Semiconductors reserves the right to make changes, without notice, in the products, including circuits, standard cells, and/or software, described or contained herein in order to improve design and/or performance. Philips Semiconductors assumes no responsibility or liability for the use of any of these products, conveys no licence or title under any patent, copyright, or mask work right to these products, and makes no representations or warranties that these products are free from patent, copyright, or mask work right infringement, unless otherwise specified.